



**COMPLETE
BOTTLING**

Welcome to **Complete Bottling**

Thank you very much for considering Complete Bottling – we started this business to offer a service that supports an increasing – and exciting – industry for British drinks producers. Whilst the quality of British drinks is on the rise, one of the factors stopping further growth is the ease by which drink producers can get their product bottled, and bottled in the way they wanted.

Complete Bottling provides its clients with the highest standards of quality – we pride ourselves on achieving consistency of high yields, desired levels of filtration, carbonation and excellent service for your bottled products.

We will be transparent and honest at all times, at Complete Bottling we are happy to discuss our processes and can be flexible to accommodate clients' needs.

We have invested in the best bottling equipment, allowing Complete Bottling full control over variables that would be difficult to achieve elsewhere such as oxidation, filtration, carbonation and cold stability.

Complete Bottling is also situated right in the heart of the country in Derby just off the M1, A50 and A38, offering great access links to deliver and return your product, minimising transport costs.

We accept quantities from 8 hectolitres upwards and can offer both sterile and bottled conditioned liquids in bottles of various shapes and sizes. We test beers on every run both prior and post bottling, to ensure quality control. Using WLD / LYS analysis, testing the product offers clarity and peace of mind over microbiological control; improving the beer production process.

Complete Bottling - Objectives

- Price match all competitors
- Highest possible yields
- Highest levels of cleanliness and sterility
- Desired clarification
- Organised structure
- Timely and reliable service
- Work with the producer at all stages
- Clear lines of communication and transparency at all times

Complete Bottling - Logistics

Complete Bottling is ideally located being based in Derby, at the centre of the UK. Our location offers excellent links to the M1, A38, A52 and A50 meaning delivering your product is cost effective, saving valuable time on the road and cost in fuel and transport. For clients further away, it makes delivery by IBC or similar container, an extremely cost effective solution.

For example, to deliver 1000L of product in IBC or container from almost anywhere in the country to Complete Bottling headquarters in Derby, costs approximately £50*. Complete Bottling offers very competitive transport rates and has a good working relationship with regional and national logistic companies. For more information on up to date prices please contact kieron@completebottling.co.uk or lizzie@completebottling.co.uk to discuss your requirements further.

*prices quoted for one way, Feb 2017

Complete Bottling - Label Specification

Complete Bottling requires as much control as possible over labels as this has the biggest impact on the efficiency by which we can bottle your product. Please consult with us before you design and buy a label as if it is outside of our specification and we are unable to apply it, charges will still apply to cover our time. The below information is not a total guarantee that the labels will be applied without any issues, but a good guide to work towards a smooth labelling process.

Please be aware that we work extremely hard at perfecting your labels, however 'perfection' is difficult to achieve and is dependent on many factors such as the material the labels are produced on, or production techniques of the label supplier. As such, on occasion there may be small imperfections.

Material

It is our preferred label type that you use polypropylene labels and as strong a backing paper as possible (PET preferred or glassine).

If you do not wish to use PP then please discuss before ordering.

Paper labels are problematic as we label before we fill, the labels can be affected by condensation that can cause the labels to crease and bubble. It is possible to buy paper that is on a plastic backing or a material that looks like paper but is a mix of PP.

Please discuss this with your label supplier.

Material thickness should be at least 80 micron.

Label types

We accept front, back, neck and wrap around labels

Proofs

Please forward all approved artwork to Complete Bottling prior to the labels being printed.

Please speak to your label printer or local authority regarding any new legal requirements as Complete Bottling does not take any responsibility for labels being supplied with incorrect legal requirements.

Dimensions

We will do our best in regards to the labels you supply us, we appreciate that you may have purchased a lot to try and keep the costs down – just be aware that the size of the label will have a direct effect on the ability of Complete Bottling to get the label on to the bottle. If the label is too big i.e. it exceeds the panel size on the bottle then the label will not look as professional as it could and may affect consumer appeal.

We have three separate stations for neck, front and back so please ensure the labels are supplied on separate rolls.

Please find below a table with our ideal label dimensions (there is some variability);

All sizes horizontal then vertical

<p>330ml Front – 65mm x 85mm Back - 65mm x 85mm Neck – <i>please ensure that your designers have designed the label to go onto to the chosen bottle, we have had instances with a 330ml neck label design that was meant for a 500ml bottle and therefore could not fit.</i> Neck – 70mm x 25mm Wrap around – 175mm x 80mm</p>	<p>500ml short 1641 Front – 75mm x 85mm Back – 75mm x 85mm Neck – 70mm x 25mm Wrap around – 200mm x 85mm</p>	<p>500ml Tall 1642 Front – 84mm x 98mm Back – 60mm x 75mm Neck – 95mm x 25mm Wrap around – 195mm x 95mm</p>
<p>Best Before Panel We apply our best before information on to the label directly, therefore we require a panel to provide this information – please allow the following dimensions: 22mm x 7mm. We can apply this Best Before section in either black or white.</p>		

Complete Bottling - Label Specification

Lot Number

We can apply a lot number as required and will be shown as a 'L****' – this is entirely down to your own personal preference.

Reel Size

Wrap around – 1000L on a reel

Front and back – 2000L on a reel

Neck – 2000L on a reel

Or 220mm diameter (max) please ask the label company to confirm.

If reel sizes exceed 220mm diameter then labels will be removed and cannot be reused.

If the label diameter is less than 190mm, an extra charge of £10 per reel will be incurred, unless authorised by Complete Bottling.

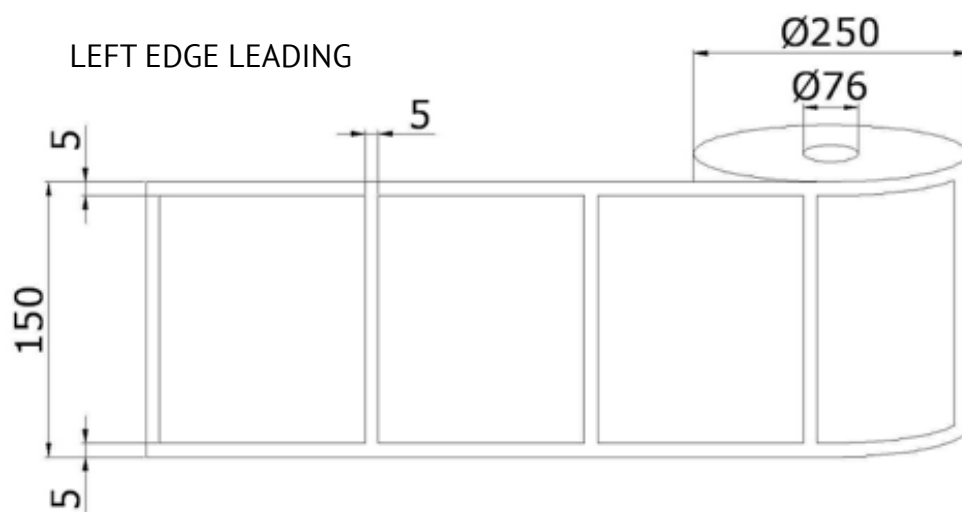

Above is the specification as given to us by our machine manufacturer in Italy. The only change is that the top and bottom of the label does not need to be a 5mm spacing and this can in reality be around 3mm only. In between spacing can also be 3mm not the stated 5mm.

Suppliers

Please call to discuss our preferred suppliers.

Complete Bottling - Crown Colours

The available crown colours are shown below.

Please note that the colours shown are just a guide and may differ slightly to the finished product.



CC4298
Racing Green



CC4309
Metallic Blue



CC4310
Yellow



CC4314
Silver



CC4315
Gold



CC4801
Shiny Gold



CC4805
Cherry Red



CC4808
Matte Silver



CC4814
Black



CC4817
Lime Green



CC4901
Purple



CC4994
Blue

www.erben.co.uk/closures/crown-caps